



CURRENT TRANSFORMERS

CTB size 3

Current transformers of CTB type are designed for indoor use at medium voltages. Epoxy resin casting (containing wounded cores inside) is the main electrical insulation. Excellent parameters of electrical insulation (including low level of partial discharges) are guaranteed.

The typical areas of application are switchgear cubicles and busducts of power generators. With regard to the possibility of sealing of the primary current conductor, CTB current transformers can be used as end-bushings of the busducts with overpressure.

The epoxy resin castings are manufactured without primary current conductors: The current conductor of busduct or switchgear is the primary winding of a current transformer. Inside diameter of the casting is 220 mm.

CTB current transformers size 3 have up to 5 cores for measuring and/or protection. CTB current transformers can be mounted in any position.



doc. INFO.CTB3 ver.b en



PLESSE Spółka Cywilna
Maciej Moskał & Dariusz Mrotek
Poland, 43-200 Pszczyna, Polne Domy 41
tel./fax +48 32 211 47 14, +48 32 447 88 33
e-mail: biuro@plesse.pl

PLESSE
INSTRUMENTS
www.plesse.pl

Example dimensional drawing of CTB current transformer size 3.

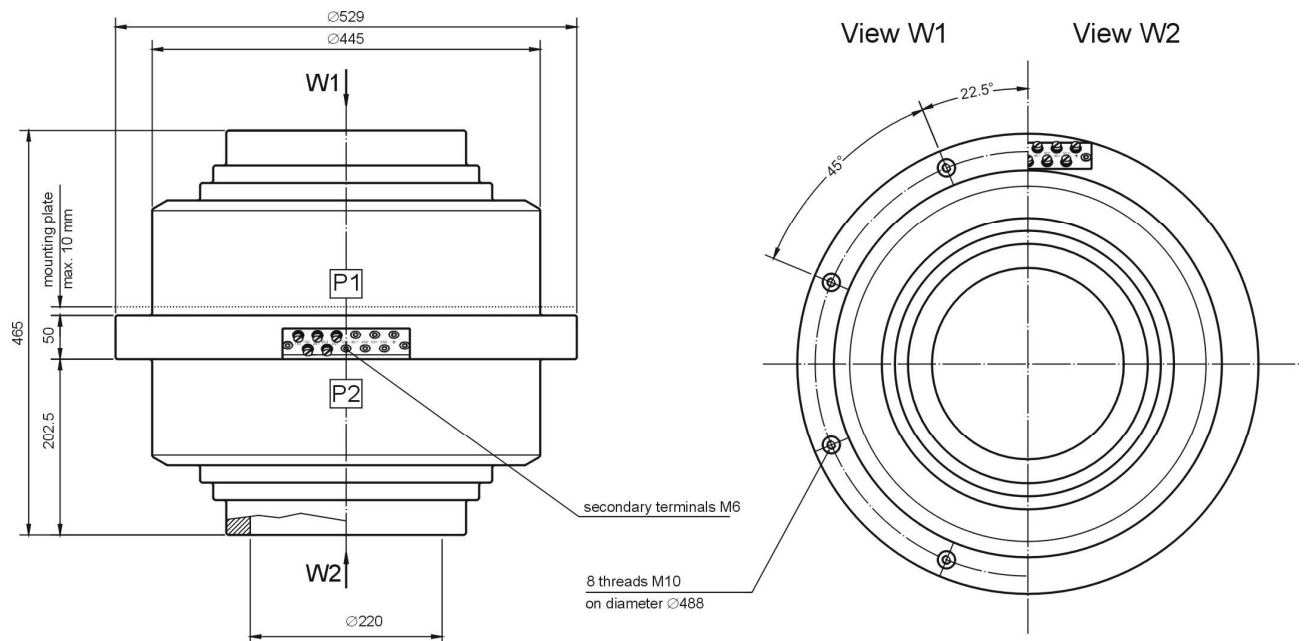

Technical data of CTB current transformers size 3.

- highest permissible system voltage **7.2/12/17.5/24 kV**
- power frequency withstand voltage, 1 min. **20/28/38/50 kV**
- impulse withstand voltage 1.2/50 μ s **60/75/95/125 kV**
- rated frequency **50 Hz**
- rated primary current I_{Pn} up to **8 000 A**
- rated short-time thermal current I_{th1s} **100 kA**
- rated dynamic current I_{dyn} **250 kA**
- number of cores up to **5**
- rated secondary currents I_{Sn} **1 A or 5 A or fractional**
- rated outputs S_n **5 ÷ 90 VA**
- accuracy classes **0.2, 0.5, 5P, 10P**
- instrument security factor (FS) **5, 10, 15**
- accuracy limit factor **10, 20, 50**
- ambient temperature **-25 ÷ 65 °C**
- weight ca **90 kg**
- according to standards **PN-EN 61869-1:2012**

NOTES: